

A

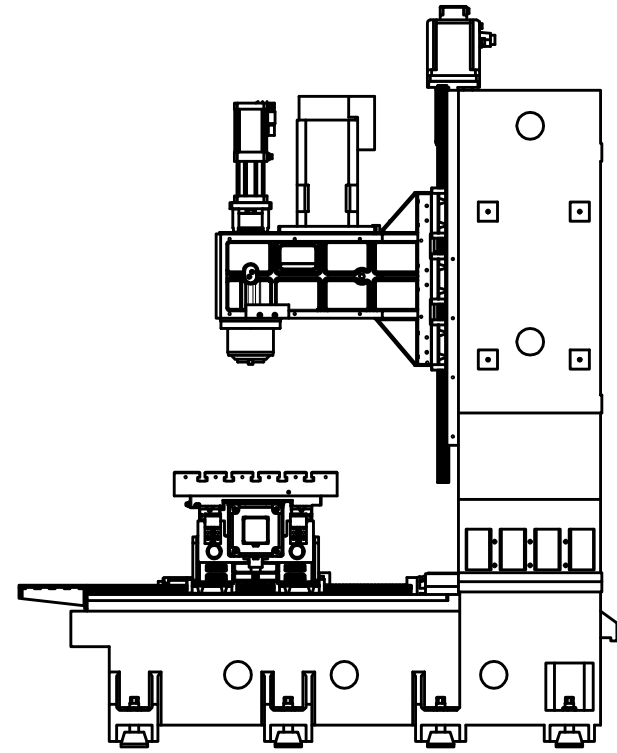

B

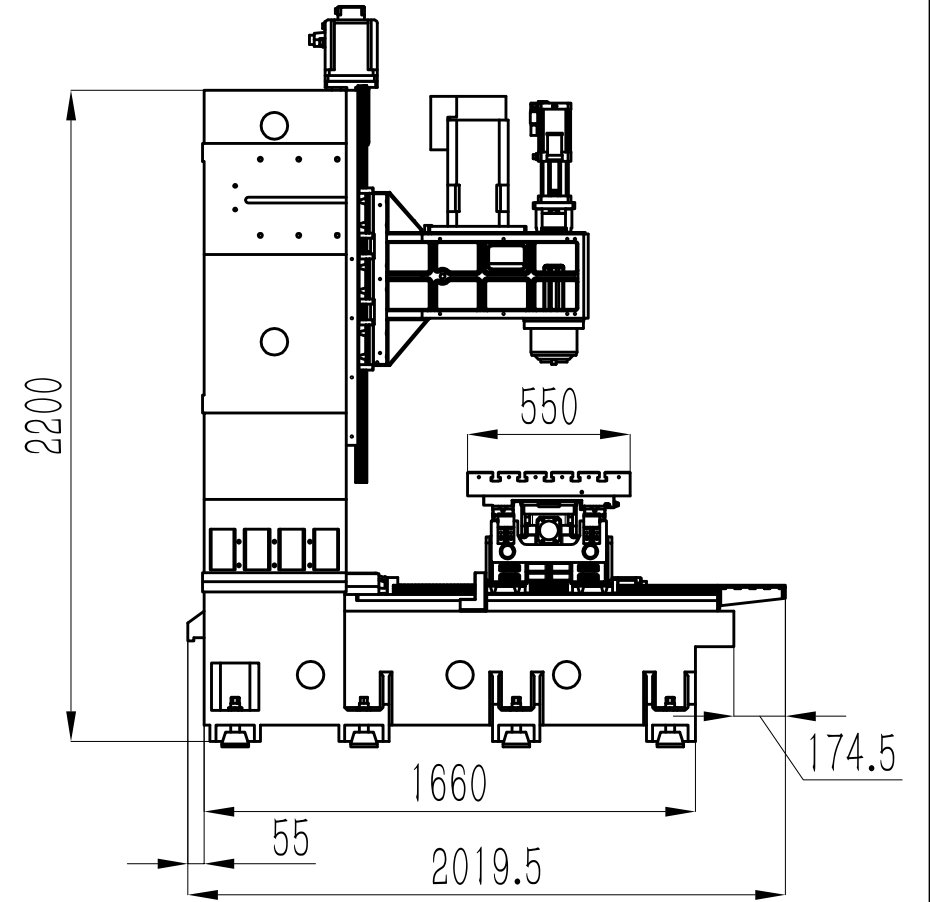
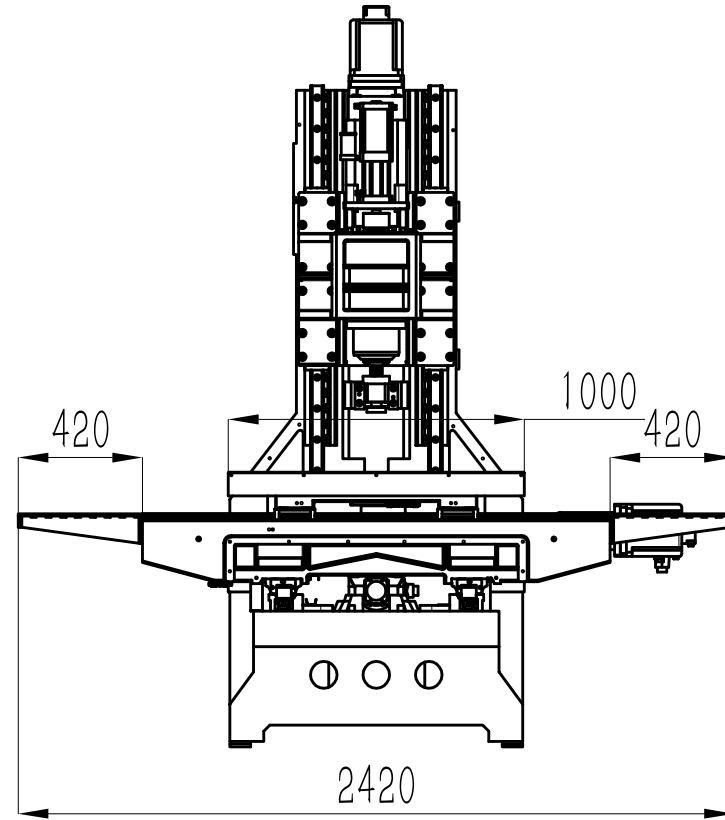

view B

B

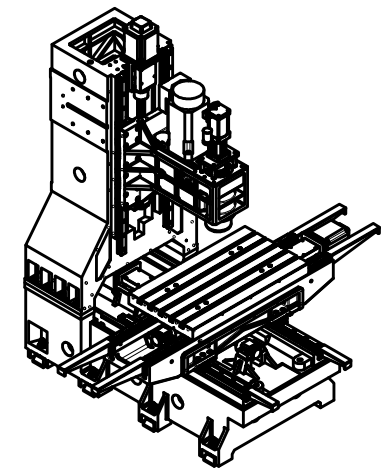
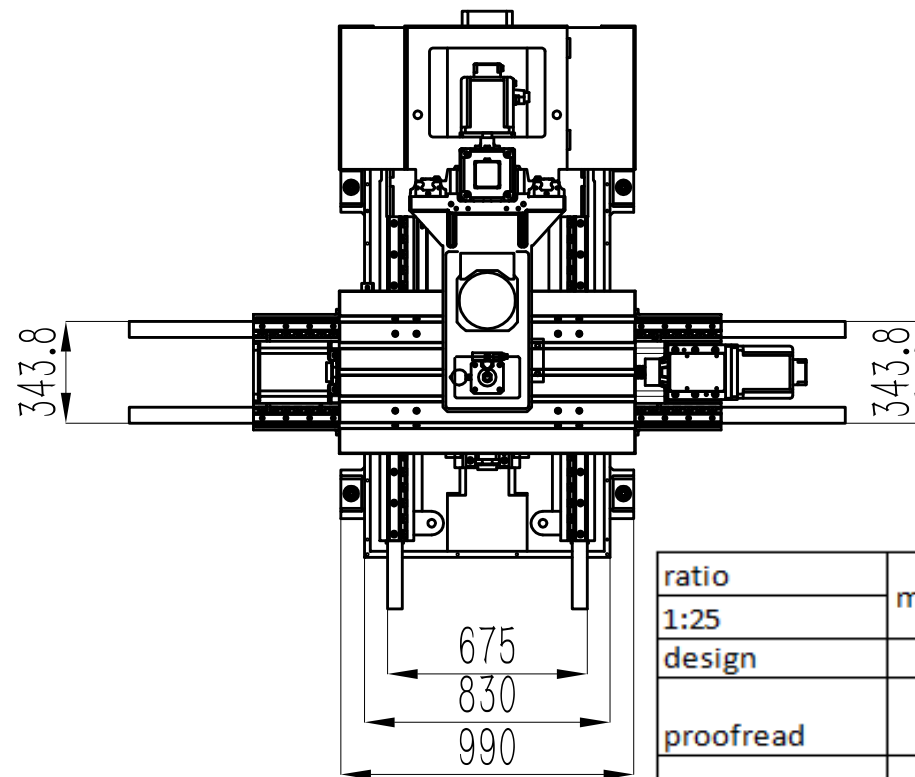
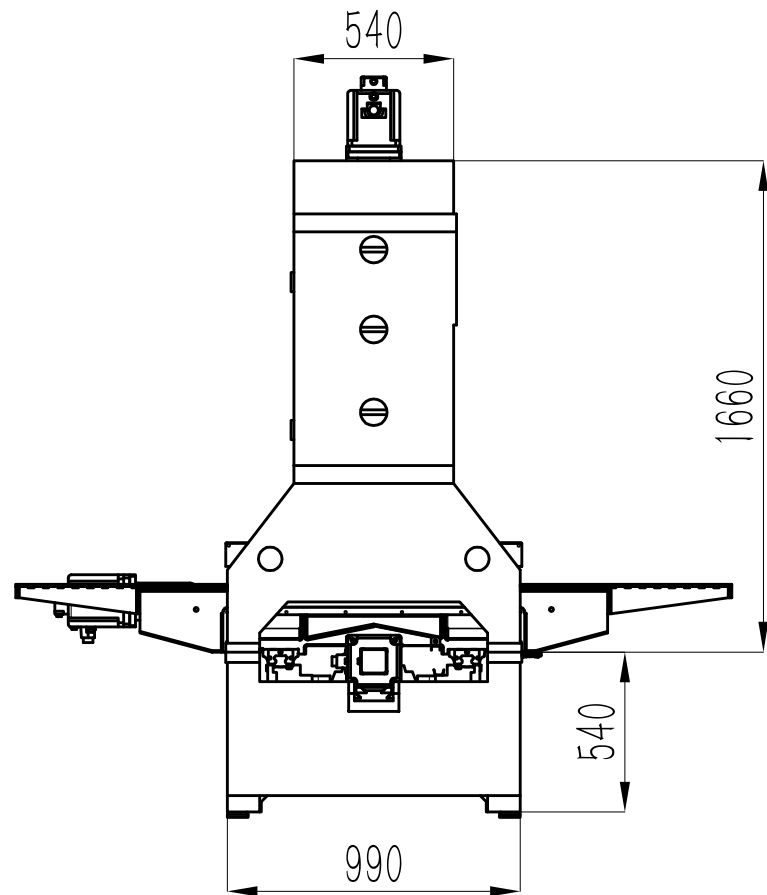

ratio	model	CTMT-LV866	Machine name	VMC	Part 1 (Group)	Total 1 page
1:25						Page 1
design			Sichuan Chentian machine tool manufacturing Co.,LTD	remarks		
proofread						
product design						
review						
Process review			division name	bare engine outside view	figure number	CTMT-LV866-001
audit						

2

3

4

A

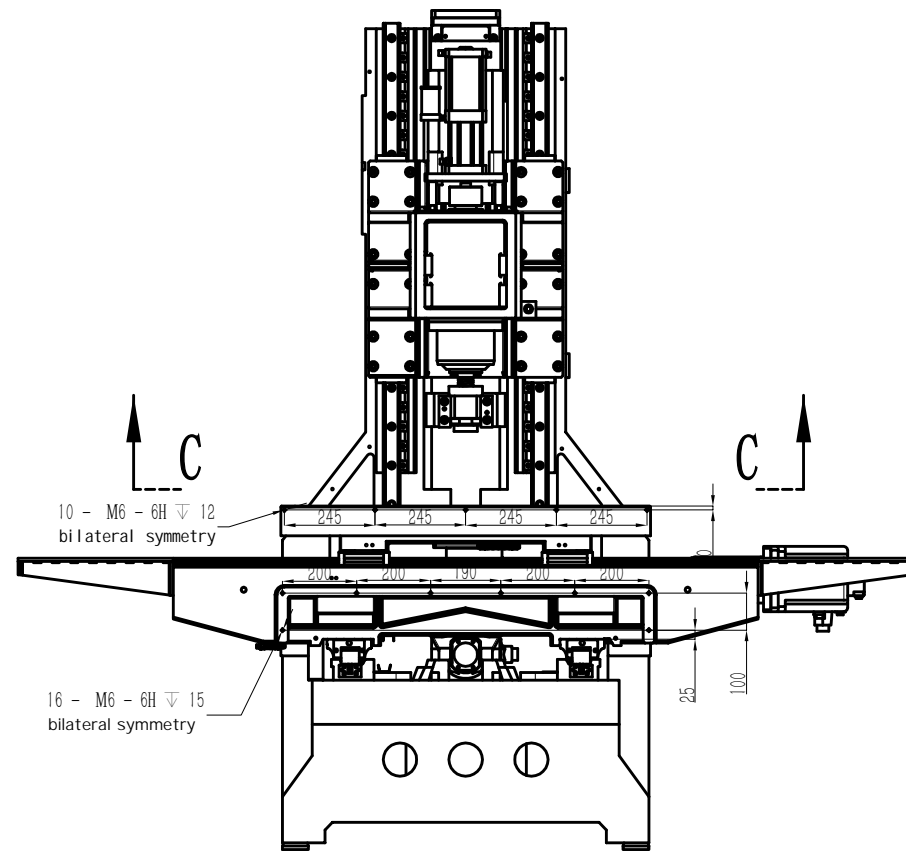

B

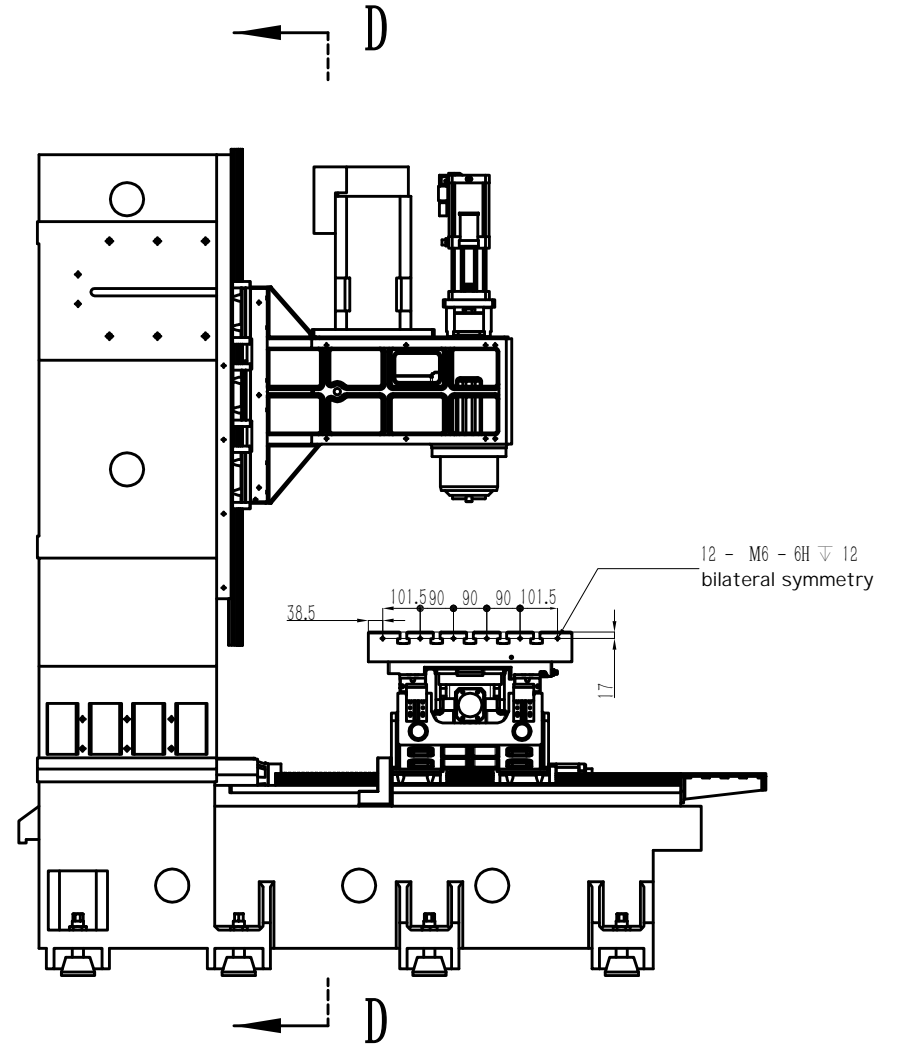
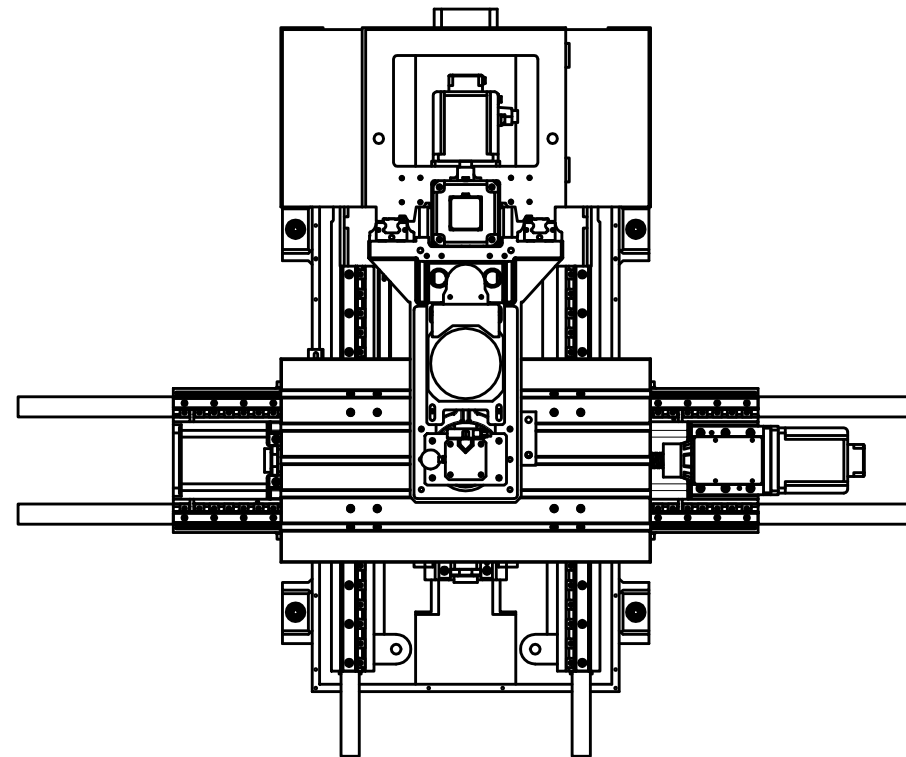

D-D

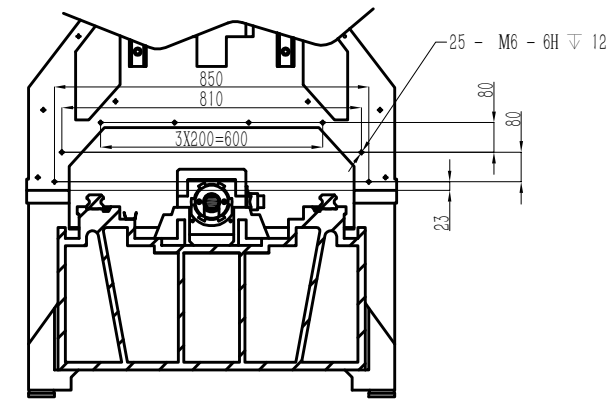

C-C

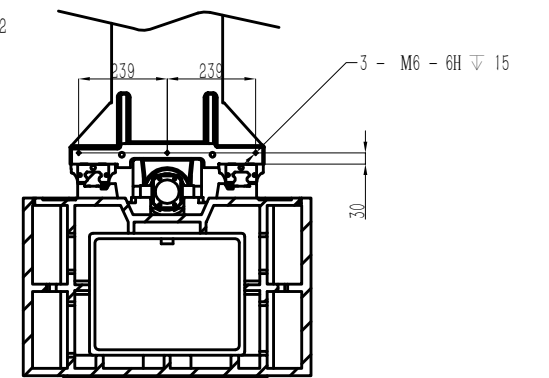

ratio 1:20 design	model CTMT-LV866	Machine name VMC	Part 1 (Group)	Total 1 page Page 1
proofread		Sichuan Chentian machine tool manufacturing Co.,LTD	remarks	X axis travel 800 Y-axis travel 600 Z-axis travel 600
product design				
review				
Process review				
audit		division name	Internal protection hole location map	figure number CTMT-LV866-004

A

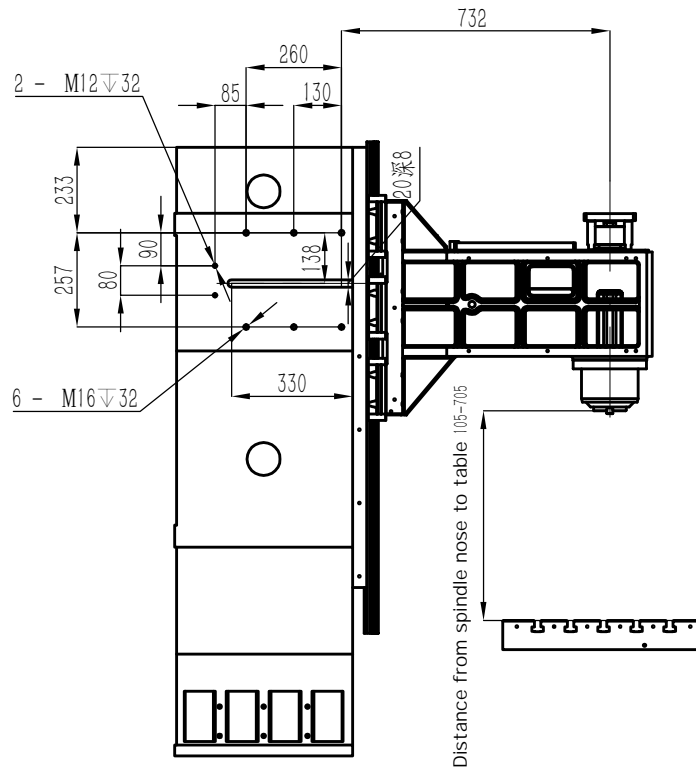

B

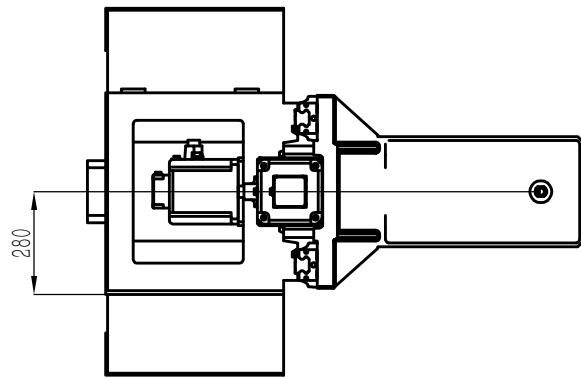

ratio	model	CTMT-LV866	Machine name	VMC	Part 1 (Group)	Total 1 page
1:20						Page 1
design			Sichuan Chentian machine tool manufacturing Co.,LTD	remarks		
proofread						
product design						
review						
Process review						
audit			division name	tool magazine hole bitmap	figure number	CTMT-LV866-002