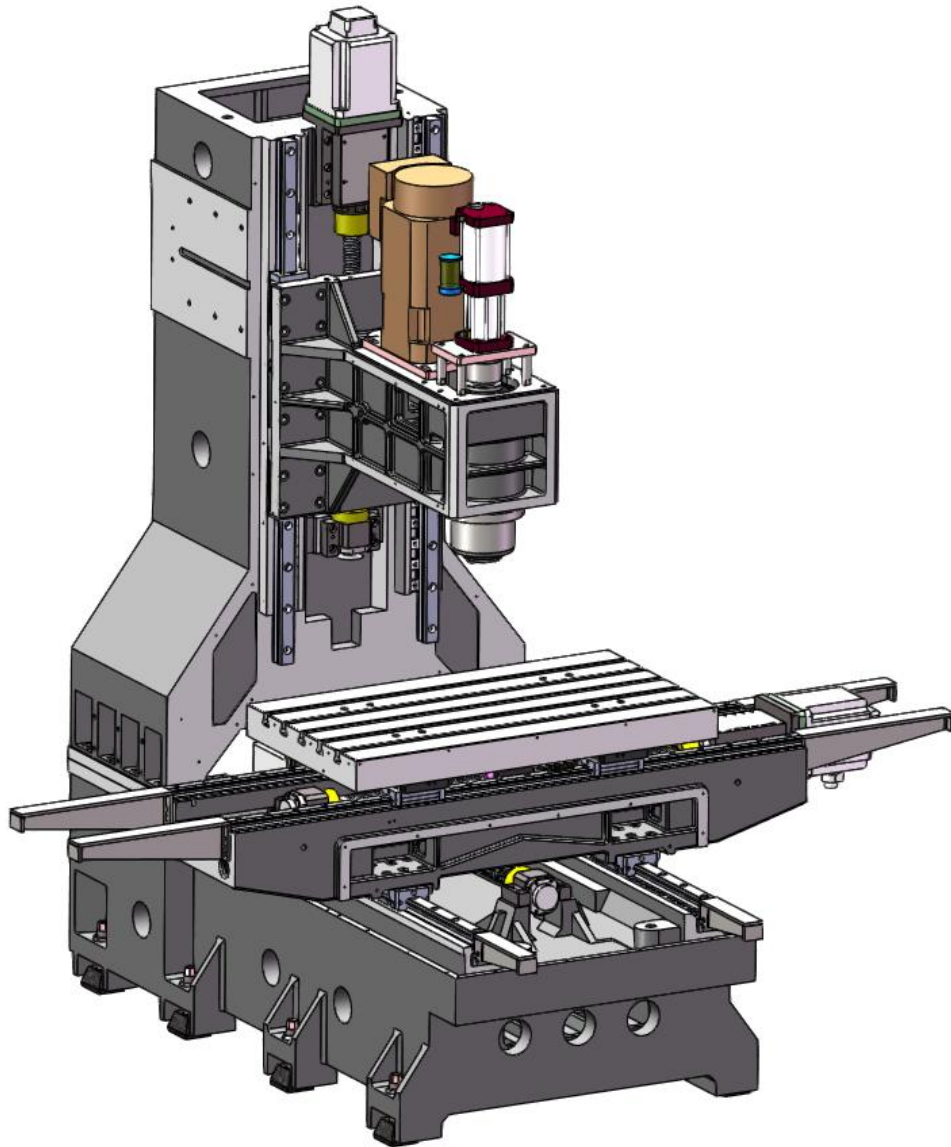

**CTMT-LV866 Main parameters**

Model		CTMT-LV866	
item			
Work surface size (mm)	<b>550 × 1000</b>		
Left and right stroke (X) (mm)	<b>800</b>		
Front and back stroke (Y) (mm)	<b>600</b>		
Up and down stroke (Z) (mm)	<b>600</b>		
Distance from spindle end face to work surface (mm)	<b>105 ~ 705</b>		
Distance from spindle center to column guide rail surface (mm)	<b>610</b>		
Table T-slots (number - size x spacing)	<b>5-18 × 90</b>		
Spindle cone hole (model/mounting size)	<b>BT40/ Ø150</b>		
Spindle speed (r/min)	<b>8000</b>		
X/Y/Z axis ball screw specifications	<b>X: 4016, Y: 4016, Z: 4016</b>		
X/Y/Z axis Fast moving speed (m/min)	<b>X: 48, Y: 48, Z: 48</b>		
X, Y, Z axis roller line rail specifications	<b>X: 35; Y: 45; Z: 45</b>		
X, Y, Z triaxial coupling specifications	<b>X, Y, Z: BK3-150</b>		
X/Y/Z motor connection	<b>Direct connection</b>		
Recommended main motor parameters (power kW)	<b>7.5</b>		
X/Y/Z axis motor parameters are recommended	Power kW	≥	<b>3, 3, 3</b>
	Torque N·m	≥	<b>12, 12, 20 (holding gate)</b>
Rail guard bracket (X, Y) (mm)	<b>X-420; Y-230;</b>		
Bed pad height (mm)	<b>50</b>		
Table weight (kg)	<b>500</b>		
Light machine net weight approx. (t)	<b>3.4</b>		
remark	<b>Y-axis motor rear</b>		

Preparation:

Proofread:

Audit: